



PROFILE PROJECTORS

V-20B / V-12B



PROFILE PROJECTOR V-20B

Large effective screen diameter of 500 mm.
Permits mounting of a large stage and includes a
built-in digital counter and digital protractor.



V-20B configured with PS 10x6B Stage

Parfocal projection lenses

All projection lenses have the same parfocal distance and feature long working distances. The built-in half mirror eliminates the need to adjust illumination each time the magnification is changed.

Maximum sample weight

Combined with the PS 10x6B stage, samples as heavy as 20 kg can be loaded.

Stage Adapter S For V-20B only

Used to mount a stage other than the PS 10x6B, PS 8x6B Stage to the V-20B profile projector.

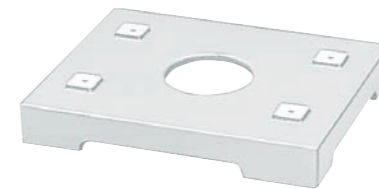

PROJECTION LENSES

Five lenses are available, each featuring a different magnification, working distance, and field of view (FOV) diameter.

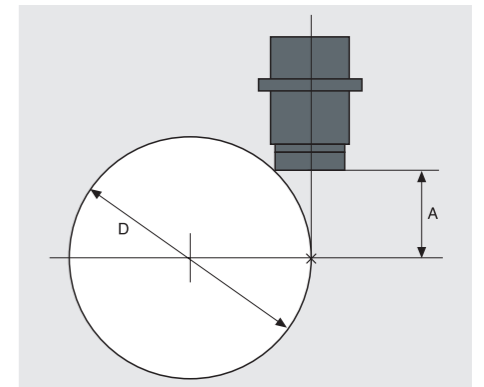

A = working distance
D = maximum diameter of a measurable cylindrical sample (mm)

Magnification	FOV diameter	Half mirror	A	D
5x	100	Built-in; fixed	73	149
10x	50	Built-in; switchable	79	215
20x	25	Built-in; switchable	85	313
50x	10	Built-in; switchable	50.5	130
100x	5	Built-in; switchable	50.5	130

*Part of the FOV is vignetted when 5x or 10x projection lens are used under diascopic illumination

SYSTEM DIAGRAM

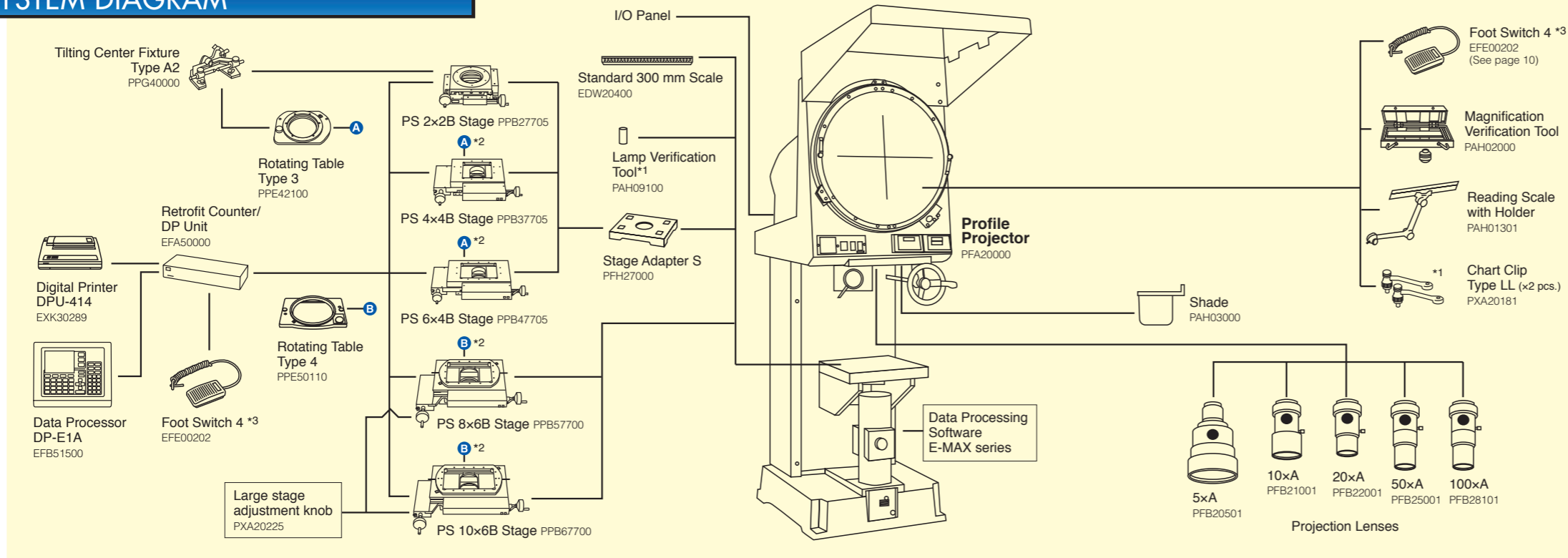

SPECIFICATIONS

Type	Vertical optical axis
Image	Inverted and reversed
Screen	ø500 mm with protractor screen
Projection lens	5x, 10x, 20x, 50x, 100x 3-lens turret mount (screw type)
Magnification accuracy	Diascopic: 0.1 % Reflected: 0.15 %
Stages	PS 10x6B, PS 8x6B directly mountable PS 6x4B, PS 4x4B, PS 2x2B mountable via adapter
Illumination	Diascopic and reflected (both 24 V-150 W halogen lamp)
Maximum sample height	150 mm
Power source	AC 100-120 V (CSA), 220-240 V (CEE), 240 V (SAA)
Dimensions(WxDxH)	570x1200x1900 mm
Weight	Approx. 260 kg

*1: Standard accessory *2: Alphabets above the stages represent accessories that can be mounted.

*3: To use the Foot Switch and [Reset/Send] buttons simultaneously, the "MM cable for simultaneous use (PXA20224)" is required.

PROFILE PROJECTOR V-12B Series

Benchtop projector with a wide measuring stroke up to 250×150 mm (cross travel). Models with a built-in digital counter and/or protractor are available.

	Built-in digital protractor	Built-in digital counter
V-12BDC	●	●
V-12BD	●	-
V-12BSC	*Fixed screen	●
V-12BS	*Fixed screen	-

Deluxe (D): built-in digital protractor **Standard (S): no digital protractor included**
Counter (C): built-in X-Y digital counter

*V-12BSC and V-12BS have a fixed screen, thus angular measurement by rotating the screen is not possible

Large stage mountable

Adapts a focusing mechanism that achieves focus by moving the objective head up and down, allowing stages with longer cross travel to be mounted. When the PS 10×6B Stage is used, the projector can measure areas as wide as 250×150 mm.

Adjustable base feet

Less affected by irregularities in the installation surface and external vibrations because the base is 2 mm away from the installation surface and the base feet are adjustable.



V-12BDC configured with PS 10×6B Stage

Increased maximum sample height

Samples as tall as 100 mm can be loaded because the rigidity of the projector is increased by its CAE design.

Built-in digital counter and protractor

V-12BDC and V-12BSC come with a digital XY counter, while V-12BDC and V-12BD have a built-in digital protractor for greater ease of use.

Erect images

Projection images are erect and unreversed for easy measurements, and their quality is as sharp as inverted images.

Switchable vertical/oblique illumination

Easier edge detection achieved with the switchable built-in reflection illuminator.

4-step zooming condenser lens with diascopic illumination

Delivers the right amount of light to suit the magnification of the projection lens. (DIA condenser needed for 200× magnification)

DIA Condenser Lens

Necessary when using 200× projection lens and diascopic illumination.



PROJECTION LENSES

Three lenses can be mounted on the rotary turret at one time. All lenses boast high resolution and minimal distortion, with long working distances.

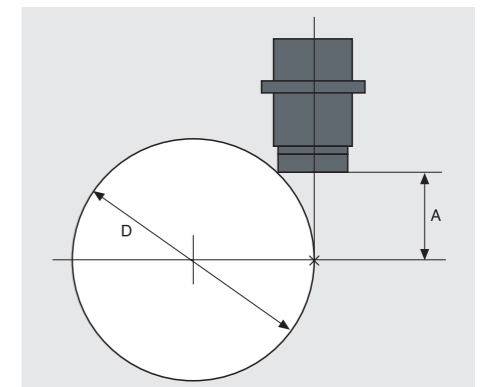

A= working distance
D= maximum diameter of a measurable cylindrical sample (mm)

Magnification	FOV diameter	Half mirror	A	D
5×	61	Built-in; fixed	60	127
10×	30	Built-in; switchable	74	215
20×	15	Built-in; switchable	74	244
25×	12	Built-in; switchable	62	178
50×	6	Built-in; switchable	61	173
100×	3	Built-in; switchable	49	123
200×	1.5	Built-in; switchable	24	49

*Part of the FOV is vignetted when 5× or 10× projection lens are used under diascopic illumination

SYSTEM DIAGRAM

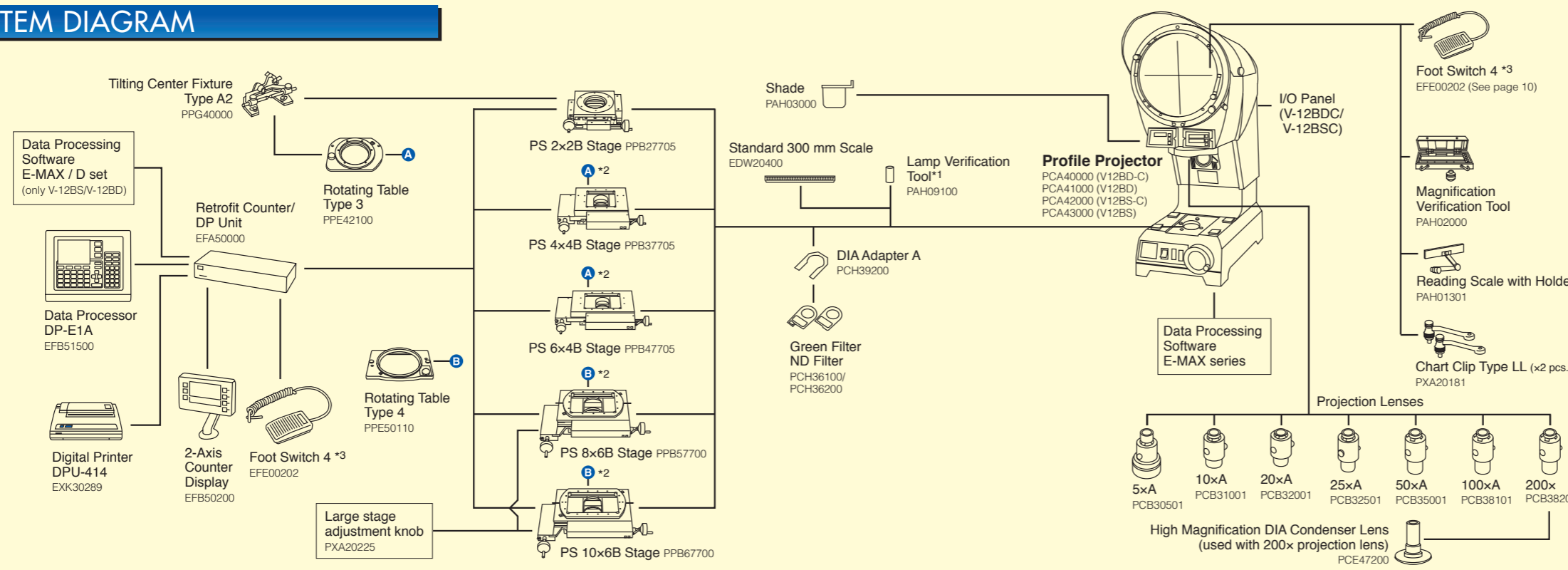

SPECIFICATIONS

Type	Vertical optical axis bench type
Image	Erect and unreversed
Screen	ø305 mm with etched center crossline V-12BDC/V-12BD: 360°rotatable screen with knob for digital protractor V-12BSC/V-12BS: fixed screen
Projection lens	5×, 10×, 20×, 25×, 50×, 100×, 200× 3-lens turret mount; clamping type
Magnification accuracy	Oblique reflected/diascopic: 0.1 % Vertical reflected: 0.15 %
Stages	PS 10×6B, PS 8×6B, PS 6×4B, PS 4×4B, PS 2×2B directly mountable
Illumination	Diascopic and reflected (both 24 V-150 W halogen lamp)
Maximum sample height	100 mm (70 mm: with PS 10×6B, PS 8×6B Stage)
Power source	AC 100/120V (50/60 Hz), AC 220/230/240V (50/60 Hz)
Dimensions(WxDxH)	410×650×938-1038 mm
Weight	Approx. 80 kg

*1: Standard accessory *2: Alphabets above the stages represent accessories that can be mounted.

*3: To use the Foot Switch and [Reset/Send] buttons simultaneously, the "MM cable for simultaneous use (PXA20224)" is required.

ACCESSORIES

Stages

PS 10×6B
(Stroke: 250×150 mm)

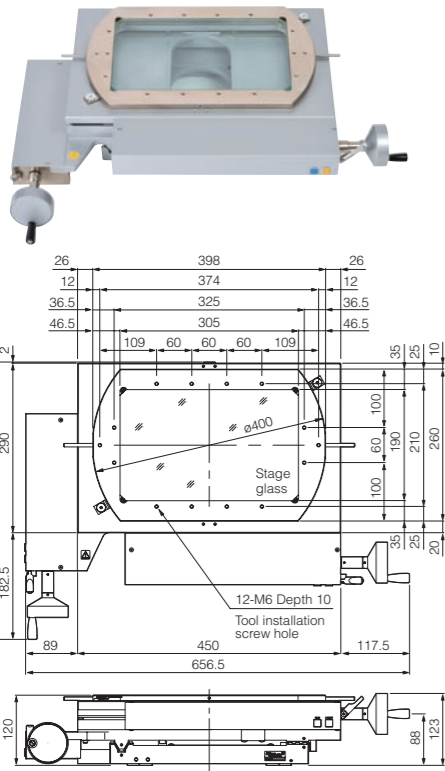

PS 8×6B
(Stroke: 200×150 mm)

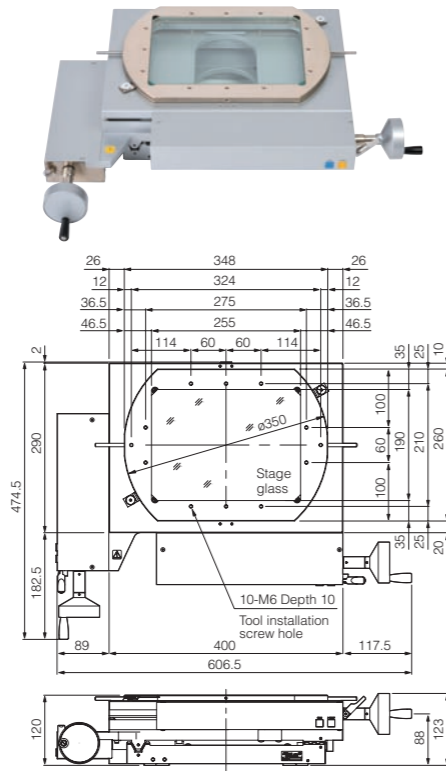

PS 6×4B
(Stroke: 150×100 mm)

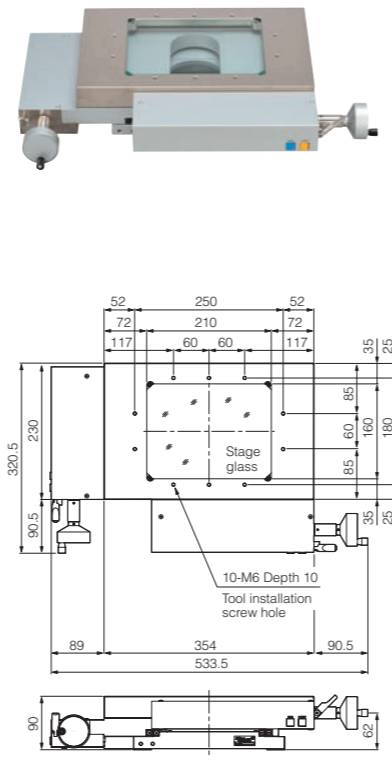

(Unit: mm)

PS 4×4B
(Stroke: 100×100 mm)

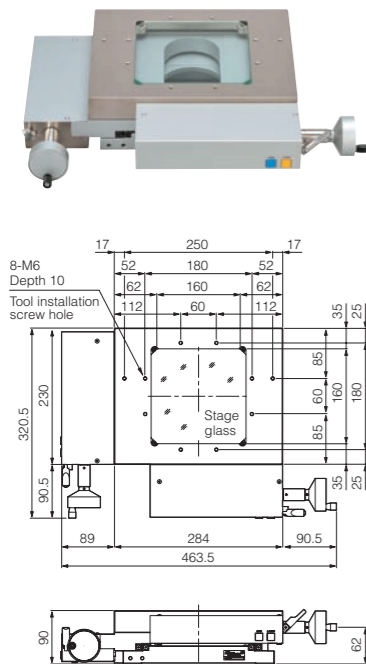

PS 2×2B
(Stroke: 50×50 mm)

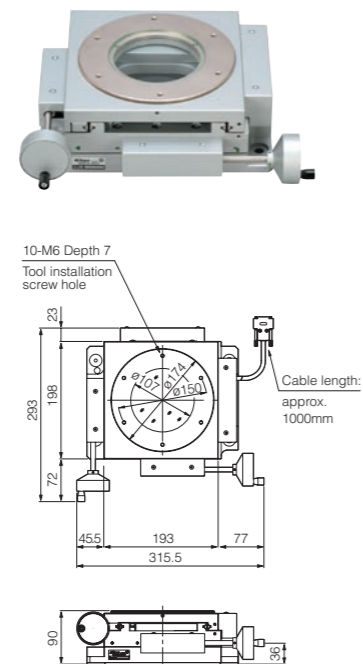

(Unit: mm)

Stage Operation

- Lever control allows for smooth changeover of coarse and fine movement.
- Swivel plate comes as standard for PS 10×6B and PS 8×6B stage.
- The course/fine changeover lever and the RESET and SEND buttons are located near the X- and Y- axis knobs.

*Not available for PS 2×2B stage



Large stage adjustment knob

- Enables fine adjustment of swivel plate rotation.

*Available for PS 10×6B and PS 8×6B stages

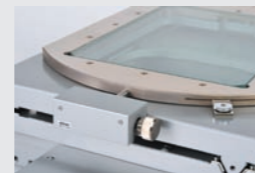

Stage Specifications

Type	Surface area (mm)	Stage glass dimensions (mm)	Stroke (mm)	Reading method	Min. reading (μm)	Rotation range	Tool installation screw hole	Loading capacity (kg)	Weight (kg)
PS 10×6B	398×260	305×190	250×150	Linear encoder	0.1	±3° (swivel plate)	12-M6 depth 10	20	51.5
PS 8×6B	348×260	255×190	200×150				10-M6 depth 10		48.5
PS 6×4B	354×230	210×160	150×100			10-M6 depth 10	15		
PS 4×4B	284×230	160×160	100×100			8-M6 depth 10	23.5		
PS 2×2B	ø174	ø107	50×50			±360° (rotation table)	6-M6 depth 7	5	15.5

Rotating Tables

Type 3

For PS 6×4B, PS 4×4B

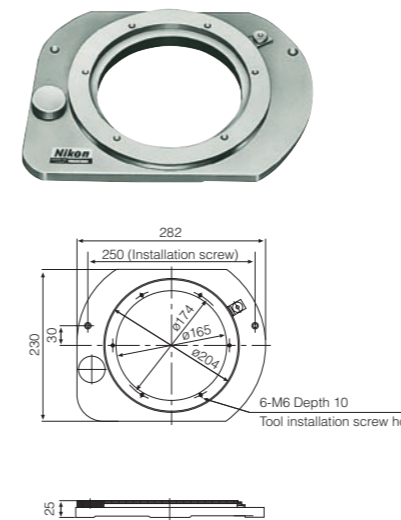

Type 4

For PS 10×6B, PS 8×6B

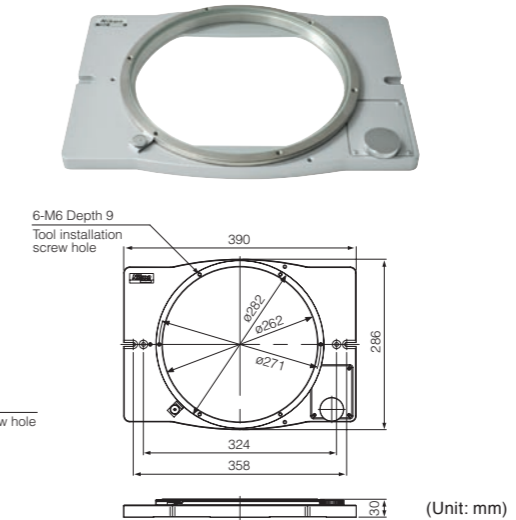

(Unit: mm)

Rotating Table Specifications

	Table diameter (mm)	Glass insert diameter (mm)	Reading range	Tool installation	Weight (Approx. kg)
Rotating Table Type 3	204	165	360° (uncalibrated)	Screw hole 6-M6	5
Rotating Table Type 4	282	262	360° (uncalibrated)	Screw hole 6-M6	8

Standard 300 mm Scale

Gauges stage travel accuracy up to 300 mm. Both 10 mm-interval sensor patterns and calibrations are provided. Made of low heat-expansion glass for minimizing influence of heat. Pitch: 10 mm (attached with calibrated value)



10 mm increments

Tilting Center Fixture A2

Used to tilt samples around the center axis. Type A2 is available for PS 2×2B with Rotating Table Type 3.



Maximum sample size diameter×length (mm)	Center height (mm)	Tilt angle	Weight (Approx. kg)
ø68×120	45	10° (in 1° increment)	2.2

ACCESSORIES

Nikon has a complete lineup of measurement support system/ data processing systems for specific purposes and applications that support data utilization.

Data Processing Software E-MAX Series

E-MAX is a series of general-purpose measurement support systems with a common user interface for PCs. The software processes 2D data from manual measuring instruments. Data result can be saved as a csv file.

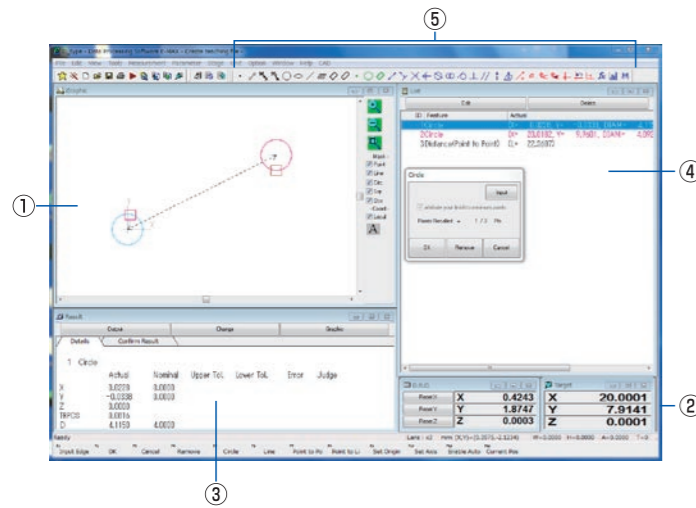

User-friendly interface allows a host of measurement and processing functions to be easily controlled using multi windows and a mouse.

- ① Graphical window
- ② Counter window
- ③ Results display window
- ④ List window
- ⑤ Toolbar (measurement codes)

*An output window, image window, and editing listing window can be displayed as necessary.

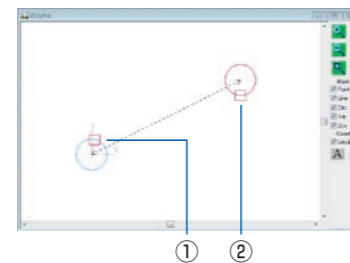

Measurement Processing

Actual measurement + recall measurement

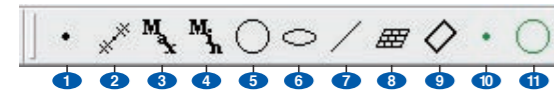

- 1. Point (X, Y, Z, E)
- 2. Midpoint (X, Y, Z)
- 3. Maximum point (X, Y, Z)
- 4. Minimum point (X, Y, Z)
- 5. Circle (X, Y, Z, R, D, E)
- 6. Ellipse (X, Y, Z, LD, SD, N1)
- 7. Line (N1, E)
- 8. Plane (N, N1, E)
- 9. Square (X, Y, Z, L1, L2, N1)
- 10. Key input point
- 11. Key input circle

Recall settings

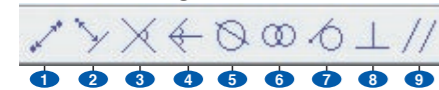

- 1. Distance between two points (L, Lx, Ly, Lz)
- 2. Distance between a point and a line (X, Y, Z, L)
- 3. Intersect of two lines (X, Y, Z, A)
- 4. Midline (N1)
- 5. Intersect of a circle and a line (X1, Y1, Z1, X2, Y2, Z2)
- 6. Intersect of two circles (X1, Y1, Z1, X2, Y2, Z2)
- 7. Contact between a point and a circle (X1, Y1, Z1, X2, Y2, Z2)
- 8. Perpendicularity (W1)
- 9. Parallelism (W1)

Recall measurement (reference settings)



- 1. Reference axis setting
- 2. XY origin setting
- 3. Coordinate system rotation 1
- 4. Coordinate system rotation 2
- 5. Coordinate system reset
- 6. Coordinate system recall 1
- 7. Coordinate system rotation 2

Name of output element
X, Y, Z: Coordinate values
E: Deviation **R:** Radius
D: Diameter **A:** Intersection angle
LD: Longest diameter
SD: Shortest diameter
L: Distance **N:** Slope from third axis
N1: Slope from first axis
W1: Geometric deviation

A built-in navigation function improves measurement efficiency by displaying the current position and the next measurement position during replays.

Number ① is the current position and number ② is the next measurement position.

E-MAX/D Set

Example combination with V-12B, E-MAX, and PC

- Specialized for processing measurement data
- Enhanced 2D data processing functions
- Can be installed on notebook PCs (D Set only)



Data Processor DP-E1A

Effectively used in combination with a profile projector and/or measuring microscope, the DP-E1A quickly calculates geometrical features with simple and interactive operations. Measurement results are automatically memorized as teaching steps and can be easily used as a measurement routine.



User-friendly, small-footprint system

Includes a measurement counter function.

Easy-to-master control keys

Controlled using measurement code buttons and measurement result lists, enabling users to easily conduct measurement.

Saves measurement results on USB memory

Teaching files and measurement results files can be saved to a USB memory device for easy access.

* Retrofit Counter/DP unit is also required

Measurement Support Application (Option)

Custom Create

For DP-E1A and Counter

Measurement data from counters and/or data processors can be transferred directly to Excel sheets.

- Compatible measuring instruments: V-20B, V-12B, MM-400/800 series, DP-E1A
- Allows data transfer to customized inspection-result sheet forms
- 3 standard inspection-result sheet forms are available

Operating environment: Windows®7 or Windows®10 / Microsoft Excel 2003 or later

Required memory: 512MB (min)

Codevelopment: Aria Co., Ltd.

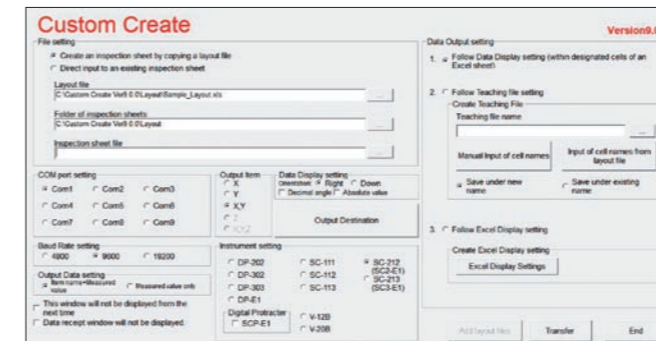

Custom Fit QC

For E-MAX

Suitable for lot control of inspection data.

- Customization of inspection result sheets are possible, in addition to the 10 standard sheets
- Graphs can be automatically generated
- Displays are adjustable between degree/minute/second
- Easy to generate histograms, X-R control charts, and scatter diagrams

Operating environment: Windows®7 or Windows®10 / Microsoft Excel 2003 or later

Required memory: 512MB (min)

Codevelopment: Aria Co., Ltd.

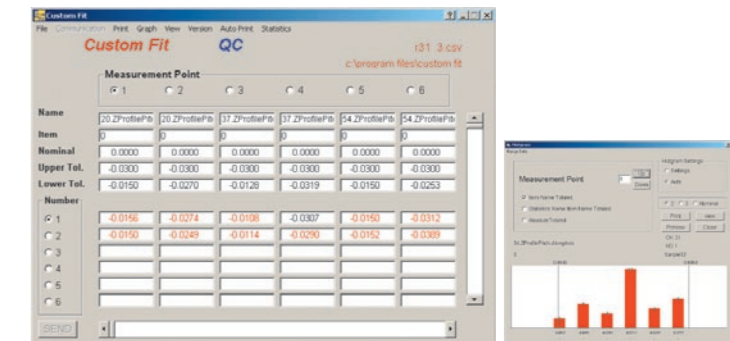

ACCESSORIES

Digital Thermal Printer DPU-414 Thermal Printer TSP654II2



	DPU-414	TSP654II2
Paper width	112 mm	58 mm or 80 mm
Applicable model/ Counter	V-20B, V-12B, SC-112, SC113, SC-212, SC-213, DP-302, DP-303, Retrofit Counter/DP Unit	

2-Axis Counter Display



These displays show X and Y- axis coordinates with Retrofit Counter/DP Unit.
(Can be switched between 1 μm, 0.1 μm, and 0.01 μm)

Glass Reading Scale



Used to measure projection images on the screen.
200 mm and 300 mm scales, both in 0.5 mm increments, are available.
Accuracy: $\pm(15+L/20)$ μm
*L = measurement length

Foot Switch 4



Used to send load command to DP-E1A and DPU-414.
Frees both hands to enhance measurement efficiency.

Retrofit Counter/DP Unit



Needed to connect DP-E1A or 2-axis counter display to V-12BD and V-12BS.

Chart Clip Type LL



Used to measure charts on the screen. Comes standard with V-12B.

Glass Scale Set

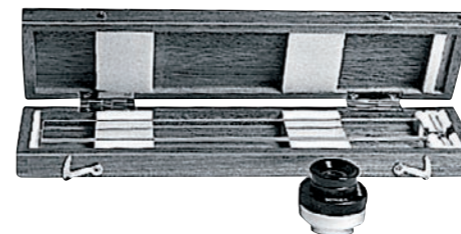

Used to check the magnifying accuracy of the projector being used. Equipped with:

- 50 mm standard scale in 1 mm increments (accuracy $\pm[3+7L/100]$ μm)
- 300 mm standard scale in 0.1 mm increments (accuracy $\pm[6+L/50]$ μm)
- 6x magnifier

*L = measurement length

Green Filter, ND Filter, DIA Adapter A

For V-12B only



DIA Adapter A ND Filter Green Filter

The green filter is used for black- and-white photography or for viewing edges of a workpiece with greater sharpness. The ND filter is used to adjust brightness. Both filters must be used with the DIA Adapter A.

3rd Party Solutions: Data Processor

Image provided by HEIDENHAIN CORPORATION



QUADRA-CHEK 2000

Display	<ul style="list-style-type: none"> • 7-inch color wide screen (15:9 multi-touch screen) • Resolution: WVGA 800x480 pixels for dialogs, inputs, position values, and graphics functions
Functions	<ul style="list-style-type: none"> • Acquisition of 2D geometry features by measurement, design and definition of geometries • Measuring point acquisition via crosshairs • Creation of measuring programs (teach-in) • Tolerance input and graphic display of measurement results • Creation and output of measurement reports • User management • Measure Magic: automatic recognition of geometries

ISO/IEC 17025 Certified

Nikon Corporation Industrial Metrology Business Unit is certified as an ISO/IEC 17025 accredited calibration laboratory for measuring projectors (profile projectors) and measuring microscopes by the Japan Accreditation Board for Conformity Assessment.

ISO/IEC 17025: International standard, which specifies the general requirements to ensure that a laboratory is competent to carry out specific tests and/or calibrations

Date of initial accreditation:	September 8, 2006
Scope of accreditation:	Measuring projectors
Accredited section:	CS 1st Engineering Section Engineering Department Industrial Metrology Business Unit
Calibration site:	Customer's laboratory (field service)
Expanded Uncertainty:	Magnification Accuracy
	5× (0.006×(100/L)×2.8)%
	10×, 20× (0.006×(100/L)×2.8)%
	50× (0.006×(100/L)×2.8)%
	100× (0.013×(100/L)×2.8)%
	X/Y-axis Indication Accuracy
	Linear scale up to 250 mm (0.70 + 5.0×10 ⁻³ ×L) μm
	Micrometer up to 50 mm 0.70 μm

Specifications and equipment are subject to change without any notice or obligation on the part of the manufacturer. September 2018 ©2006-2018 NIKON CORPORATION

N.B. Export of the products* in this catalog is controlled under the Japanese Foreign Exchange and Foreign Trade Law. Appropriate export procedures shall be required in case of export from Japan.

*Products: Hardware and its technical information (including software)



WARNING

TO ENSURE CORRECT USAGE, READ THE CORRESPONDING MANUALS CAREFULLY BEFORE USING THE EQUIPMENT.



NIKON CORPORATION

Shinagawa Intercity Tower C, 2-15-3, Konan, Minato-ku, Tokyo 108-6290, Japan
phone: +81-3-6433-3701 fax: +81-3-6433-3784

<https://www.nikon.com/products/industrial-metrology/>

ISO 14001 Certified
for NIKON CORPORATION

ISO 9001 Certified
for NIKON CORPORATION
Industrial Metrology Business Unit

NIKON METROLOGY EUROPE NV

Geldenaaksebaan 329, 3001 Leuven, Belgium
phone: +32-16-74-01-00 fax: +32-16-74-01-03

E-mail: Sales.Europe.NM@nikon.com

<http://www.nikonmetrology.com/en-gb>

NIKON METROLOGY UK LTD.

UNITED KINGDOM phone: +44-1332-811-349 fax: +44-1332-639-881

E-mail: Sales.UK.NM@nikon.com

NIKON METROLOGY SARL

FRANCE phone: +33-1-60-86-09-76 fax: +33-1-60-86-57-35

E-mail: Sales.France.NM@nikon.com

NIKON METROLOGY GMBH

GERMANY phone: +49-6023-91733-0 fax: +49-6023-91733-229

E-mail: Sales.Germany.NM@nikon.com

NIKON INSTRUMENTS S.p.A.

ITALY phone: +39-055-300-96-01 fax: +39-055-30-09-93

NIKON METROLOGY, INC.

12701 Grand River Avenue, Brighton, MI 48116 U.S.A.

phone: +1-810-220-4360 fax: +1-810-220-4300

E-mail: sales.nm-us@nikon.com

<http://www.nikonmetrology.com/en-us>

NIKON CANADA INC.

CANADA phone: +1-905-602-9676 fax: +1-905-602-9953

NIKON SINGAPORE PTE LTD.

SINGAPORE phone: +65-6559-3651 fax: +65-6559-3668

E-mail: NSG.Industrial-sales@nikon.com

NIKON MALAYSIA SDN BHD

MALAYSIA phone: +60-3-7809-3688 fax: +60-3-7809-3633

PT. NIKON INDONESIA

INDONESIA phone: +62-267-864-3949 fax: +62-267-864-3950

E-mail: PTN.Instruments@nikon.com

NIKON SALES (THAILAND) CO., LTD.

THAILAND phone: +66-2633-5100 fax: 66-2633-5191

NIKON INDIA PRIVATE LIMITED

INDIA phone: +91-124-4688500 fax: +91-124-4688527

NIKON INSTRUMENTS (SHANGHAI) CO., LTD.

CHINA (Shanghai branch) phone: +86-21-6841-2050 fax: +86-21-6841-2060

(Beijing branch) phone: +86-10-5831-2028 fax: +86-10-5831-2026

(Guangzhou branch) phone: +86-20-3882-0551 fax: +86-20-3882-0580

NIKON INSTRUMENTS KOREA CO., LTD.

KOREA phone: +82-2-2186-8400 fax: +82-2-555-4415